

16-bit and 20-bit, 8-pin $\Delta\Sigma$ ADCs

Features

- Delta-sigma Analog-to-digital Converter
 - Linearity Error: 0.0015% FS
 - Noise-free Resolution: Up to 17 Bits
- Differential Bipolar Analog Inputs
- V_{REF} Input Range from 250 mV to 5 V
- 50/60 Hz Simultaneous Rejection (CS5510/12)
- 16 to 326 Sps Output Word Rate
- On-chip Oscillator (CS5511/13)
- Power Supply Configurations:
 - $V_+ = 5\text{ V}$, $V_- = 0\text{ V}$
 - Multiple Dual-supply Arrangements
- Low Power Consumption
 - Normal Mode, 2.5 mW
 - Sleep Mode, 10 μW
- Low-cost, Compact, 8-pin Package
- Lead-free Device Package Options

General Description

The CS5510/11/12/13 are low-cost, easy-to-use, $\Delta\Sigma$ analog-to-digital converters (ADCs) which use charge-balance techniques to achieve 16-bit (CS5510/11) and 20-bit (CS5512/13) performance. The ADCs are available in a space-efficient, 8-pin SOIC package and are optimized for measuring signals in weigh scale, process control, and other industrial applications.

To accommodate these applications, the ADCs include a fourth-order $\Delta\Sigma$ modulator and a digital filter. When configured with an external master clock of 32.768 kHz, the filter in the CS5510/12 provides better than 80 dB of simultaneous 50 and 60 Hz line rejection, and outputs conversion words at 53.5 Sps. The CS5511/13 include an on-chip oscillator which eliminates the need for an external clock source.

Low-power, flexible supply configurations, compact pinout, and ease of use make these products ideal solutions for cost-conscience and space-constrained applications.

ORDERING INFORMATION

See [page 23](#).

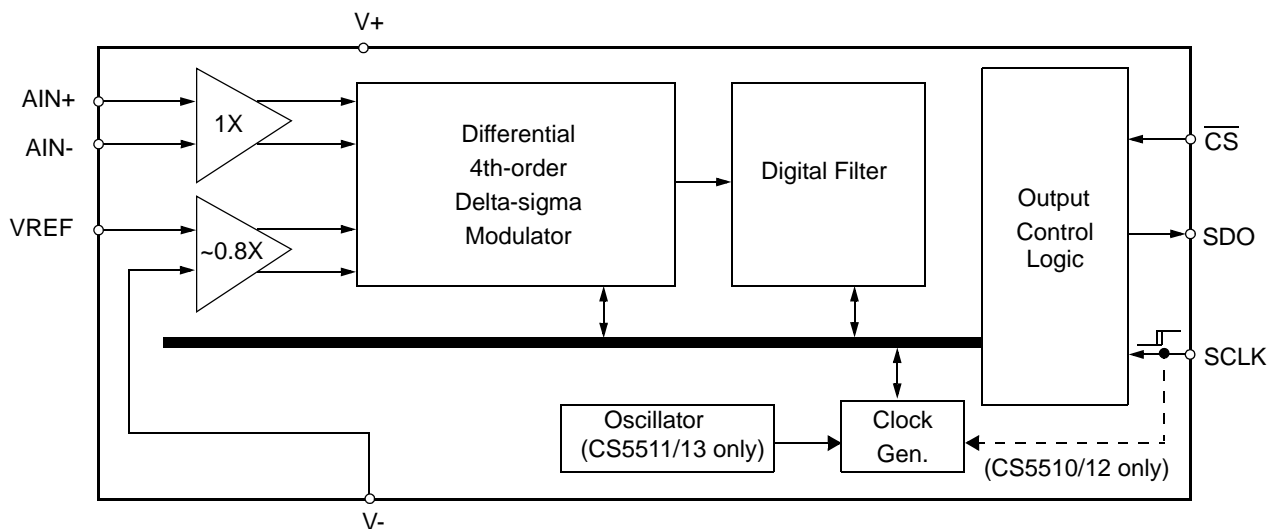

TABLE OF CONTENTS

1. CHARACTERISTICS AND SPECIFICATIONS	4
ANALOG CHARACTERISTICS	4
DIGITAL CHARACTERISTICS	5
DYNAMIC CHARACTERISTICS	6
ABSOLUTE MAXIMUM RATINGS	6
SWITCHING CHARACTERISTICS - CS5510/12	7
SWITCHING CHARACTERISTICS - CS5511/13	8
2. GENERAL DESCRIPTION	10
2.1 Analog Input	10
2.1.1 Analog Input Model	10
2.2 Voltage Reference Input	10
2.2.1 Voltage Reference Input Model	11
2.3 Power Supply Arrangements	11
2.3.1 Digital Logic Levels	11
2.4 Clock Generator	14
2.4.1 External Clock Source for CS5510/12	14
2.4.2 Internal Oscillator for CS5511/13	14
2.5 Performing Conversions	15
2.5.1 Reading Conversions - CS5510/12	16
2.5.2 Reading Conversions - CS5511/13	16
2.5.3 Output Coding	17
2.5.4 Digital Filter	18
2.5.5 Multiplexed Applications	19
2.6 Digital Off-chip System Calibration	20
2.7 Power Consumption, Sleep and Reset	20
2.8 PCB Layout	20
3. PIN DESCRIPTIONS	21
4. SPECIFICATION DEFINITIONS	22
5. ORDERING INFORMATION	23
6. ENVIRONMENTAL, MANUFACTURING, & HANDLING INFORMATION	23
7. PACKAGE DIMENSIONS	24
8. REVISION HISTORY	25

LIST OF FIGURES

Figure 1. SDO Read Timing CS5510/12	9
Figure 2. SDO Read Timing CS5511/13	9
Figure 3. Input models for AIN+ and AIN- pins.	10
Figure 4. CS5512/13 Measured Noise-Free Bits vs. VREF.	11
Figure 5. Input model for VREF pin.....	11
Figure 6. CS5510/11/12/13 Configured with a +5.0 V Analog Supply.	12
Figure 7. CS5510/11/12/13 Configured with ± 2.5 V Analog Supplies.....	12
Figure 8. CS5510/11/12/13 Configured with $V_+ = +3.3$ V and $V_- = -1.7$ V; or $V_+ = +3.0$ V and $V_- = -2.0$ V.	13
Figure 9. \overline{CS} and SCLK Digital Input Levels.	14
Figure 10. SDO Digital Output Levels.	14
Figure 11. Serial Port Output Drive Logic.	14
Figure 12. External (CMOS Compatible) Clock Source.	15
Figure 13. Using a Microcontroller as a Clock Source.	15
Figure 14. Typical Linearity Error for CS5510.....	15
Figure 15. Typical Linearity Error for CS5512.....	15
Figure 16. Data Word Timing for the CS5510.....	16
Figure 17. Data Word Timing for the CS5511.....	17
Figure 18. Data Word Timing for the CS5512.....	17
Figure 19. Data Word Timing for the CS5513.....	17
Figure 20. Digital Filter Response.....	19

LIST OF TABLES

Table 1. CS5512/13 Output Conversion Data Register Description (Flags + 20 bits).	18
Table 2. CS5510/11 Output Conversion Data Register Description (Flags + 16 bits).	18
Table 3. CS5510/11/12/13 Output Coding.....	18
Table 4. Digital Filter Response at 32.768 kHz.....	19

1. CHARACTERISTICS AND SPECIFICATIONS

ANALOG CHARACTERISTICS

($T_A = 25^\circ\text{C}$; $V_+ = 5\text{ V} \pm 5\%$; $V_- = 0\text{ V}$; $V_{REF} = 2.5\text{ V}$ (relative to V_-);

CS5510/12, $SCLK = 32.768\text{ kHz}$; CS5511/13, $f_{osc} = 64\text{ kHz} \pm 32\text{ kHz}$; OWR (Output Word Rate) = 53.5 Sps for CS5510/12; OWR = 107 Sps $\pm 50\%$ for CS5511/13)

(See Note 1.)

Parameter	Min	Typ	Max	Unit
Accuracy				
Linearity Error (CS5510/11)	-	± 0.0015	± 0.003	% FS
Linearity Error (CS5512/13)	-	± 0.0007	± 0.0015	% FS
No Missing Codes (CS5510/11)	16	-	-	Bits
No Missing Codes (CS5512/13)	20	-	-	Bits
Bipolar Offset (CS5510/11) (Note 2)	-	± 3	± 7	LSB_{16}
Bipolar Offset (CS5512/13) (Note 2)	-	± 40	± 100	LSB_{20}
Offset Drift Over Temperature (Notes 2 and 3)	-	60	-	$nV/^\circ\text{C}$
Gain Drift Over Temperature (Note 3)	-	1	-	$ppm/^\circ\text{C}$
Analog Input				
Common Mode + Signal on AIN+ or AIN- Dual Supply	V_-	-	V_+	V
Input Range (Bipolar) $ (AIN+ - AIN-)/(V_{REF} - V_-) $	72	80	88	% V_{REF}
Common Mode Rejection	dc	-	120	dB
	50, 60Hz (CS5510/12)	-	120	dB
Input Capacitance	-	12	-	pF
CVF Current AIN+, AIN- (Note 6)	-	10	-	nA

Typical Noise (Notes 4, 5 and 7)		
Output Word Rate (Hz)	-3 dB Filter Frequency (Hz)	Noise ($\mu\text{V RMS}$)
53.5	12.5	7.5

- Notes:
- Specifications guaranteed by design, characterization, and/or test.
 - Specification applies to the device only and does not include any effects by external parasitic thermocouples.
 - Drift over specified temperature range after power-up at 25°C .
 - Wideband noise aliased into the baseband. Referred to the input. Typical values shown for 25°C .
 - For peak-to-peak noise multiply by 6.6.
 - See the section of the data sheet which discusses Analog Input Models.
 - For CS5511/13, OWR = 107 Sps $\pm 50\%$.

Specifications are subject to change without notice.

ANALOG CHARACTERISTICS (Continued)

Parameter		Min	Typ	Max	Unit
Voltage Reference Input					
Range	{(VREF) - (V-)} (Note 8)	0.250	2.5	(V+) - (V-)	V
Input Capacitance		-	7	-	pF
CVF current		-	6	-	nA
Power Supplies					
Supply Voltages	{(V+) - (V-)}	4.75	5	5.25	V
DC Power Supply Currents	(Note 9)				
I_{V+}	CS5510	-	275	360	μ A
	CS5511	-	290	380	μ A
	CS5512	-	360	470	μ A
	CS5513	-	385	500	μ A
I_{V-}	CS5510	-	275	360	μ A
	CS5511	-	290	380	μ A
	CS5512	-	360	470	μ A
	CS5513	-	385	500	μ A
Power Consumption	(Note 10)				
	CS5510	-	1.4	1.9	mW
	CS5511	-	1.5	2.0	mW
	CS5512	-	1.8	2.5	mW
	CS5513	-	1.9	2.7	mW
Sleep	(Note 11)	-	10	-	μ W
Power Supply Rejection	dc Positive Supply	-	85	-	dB
	dc Negative Supply	-	85	-	dB

Notes: 8. VREF is referenced to V- and must be less than or equal to V+.

9. Due to current through the CS pin, I_{V+} and I_{V-} may not always be the same value.

10. All outputs unloaded. All inputs CMOS levels ($> (V+ - 0.6 V)$ or $< (V- + 0.6 V)$).

11. CS must be inactive (logic high) during sleep to meet this power specification.

DIGITAL CHARACTERISTICS

($T_A = 25^\circ C$; $V+ = 5 V \pm 5\%$; $V- = 0 V$) (See Notes 1 and 12.)

Parameter	Symbol	Min	Typ	Max	Unit
High-Level Input Voltage:	CS and SCLK V_{IH}	$V+ - 0.45$	-	-	V
Low-Level Input Voltage:	(Note 13) CS CS_{Low}	-	-	V_{L1}	V
	SCLK V_{IL}	-	-	V_{L1}	V
Input Current:	(Note 14) CS I_{CS}	-	-	1.0	mA
High-Level Output Voltage:	SDO, $I_{source} = 5.0mA$ V_{OH}	$(V+) - 0.6$	-	-	V
Low-Level Output Voltage:	(Note 14) SDO, $I_{sink} = 1.0mA$ V_{OL}	-	-	$(CS_{Low}) + 0.6$	V
Input Leakage Current	SCLK I_{in}	-	± 0.015	± 10	μ A
3-State Leakage Current	SCLK I_{OZ}	-	-	± 10	μ A

Notes: 12. All measurements performed under static conditions.

13. V_{L1} is $0.5 (V+ - V-) + 0.6 V + V-$.

14. The CS signal provides the sink current path for the SDO pin when CS is low. The external drive logic to CS, therefore, must be able to handle the logic-low current drive levels for all devices attached to SDO. The voltage specified for SDO is relative to CS_{Low}. See Section 2.3.1, "Digital Logic Levels" and Figure 11 for more details.

DYNAMIC CHARACTERISTICS

Parameter	Symbol	Ratio	Units
Modulator Sampling Frequency	CS5510/12 f_s	SCLK/4	Hz
	CS5511/13 f_s	$f_{osc}/4$	Hz
Output Word Rate	CS5510/12 OWR	SCLK/612	Sps
	CS5511/13 OWR	$f_{osc}/612$	Sps
Filter Settling Time to 1/2 LSB (Full Scale Step)	t_s	4/OWR	s

ABSOLUTE MAXIMUM RATINGS

(V- = 0 V) (See Note 15.)

Parameter	Symbol	Min	Typ	Max	Unit
DC Power Supplies (Note 16)	Positive V+	-0.3	-	+6.0	V
	Negative V-	-6.0	-	+0.3	V
Input Current, Any Pin Except Supplies (Notes 17 and 18)	I_{IN}	-	-	± 10	mA
Output Current	I_{OUT}	-	-	± 25	mA
Package Power Dissipation (Note 19)	PDN	-	-	400	mW
Analog Input Voltage AIN pins	V_{INA}	(V-)+(-0.3)	-	(V+)+0.3	V
Digital Input Voltage	V_{IND}	(V-)+(-0.3)	-	(V+)+0.3	V
Ambient Operating Temperature	T_A	-40	-	+85	°C
Storage Temperature	T_{stg}	-65	-	+150	°C

Notes: 15. All voltages with respect to V-.

16. V+ and V- must satisfy $0.0V \leq \{(V+) - (V-)\} \leq +6.0V$.

17. Applies to all pins including continuous overvoltage conditions at the analog input (AIN) pins.

18. Transient current of up to 100 mA will not cause SCR latch-up. Maximum input current for a power supply pin is ± 50 mA.

19. Total power dissipation, including all input currents and output currents.

WARNING: Operation at or beyond these limits may result in permanent damage to the device.

Normal operation is not guaranteed at these extremes.

SWITCHING CHARACTERISTICS - CS5510/12

($T_A = 25^\circ\text{C}$; $V_+ = 5\text{ V} \pm 5\%$; $V_- = 0\text{ V}$; Input Levels: Logic 0 = 0 V, Logic 1 = V_+ ; $C_L = 50\text{ pF}$)

Parameter	Symbol	Min	Typ	Max	Unit
Master Clock Timing					
Master Clock Frequency (CS5510) (Note 20)	SCLK	10	32.768	130	kHz
Master Clock Frequency (CS5512) (Note 20)	SCLK	10	32.768	200	kHz
Master Clock Duty Cycle		40	-	60	%
Rise Times (Note 21)	t_{rise}	-	-	1.0	μs
CSB		-	-	10	μs
SCLK		-	50	-	ns
SDO		-	50	-	ns
Fall Times (Note 21)	t_{fall}	-	-	1.0	μs
CSB		-	-	10	μs
SCLK		-	50	-	ns
SDO		-	50	-	ns
Serial Port Timing					
Serial Clock Frequency (CS5510) (Note 22)	SCLK	10	32.768	130	kHz
Serial Clock Frequency (CS5512) (Note 22)	SCLK	10	32.768	200	kHz
SCLK High to Enter Sleep (Note 22)	t_{SLP}	200	-	2000	μs
SCLK Low to Exit Sleep (Note 22)	t_{WAKE}	10	-	-	μs
Serial Clock Pulse Width High	t_1	2	-	60	μs
Pulse Width Low	t_2	2	-	60	μs
SDO Read Timing					
$\overline{\text{CS}}$ to Data Valid	t_3	-	-	150	ns
SCLK Falling to New Data Bit	t_4	-	-	150	ns
$\overline{\text{CS}}$ Rising to SDO Hi-Z	t_5	-	-	150	ns
$\overline{\text{CS}}$ Falling to SCLK Rising	t_{11}	200	-	-	ns

Notes: 20. Device parameters are specified with 32.768 kHz clock; however, clocks up to 130 kHz (CS5510) or 200 kHz (CS5512) can be used for increased throughput. Higher clock rates will result in degraded linearity specifications, as shown in Figures 14 and 15.

21. Specified using 10% and 90% points on waveform of interest. Output loaded with 50 pF.

22. On the CS5510/12, the serial clock input (SCLK) provides the master clock to operate the converter as well as the serial data clock used to read conversion data. If SCLK is held high (logic 1) for t_{SLP} or longer, the CS5510/12 enters sleep. To exit from sleep mode, SCLK must be held low (logic 0) for t_{WAKE} or longer.

SWITCHING CHARACTERISTICS - CS5511/13

 (T_A = 25° C; V₊ = 5 V ±5%; V₋ = 0 V; Input Levels: Logic 0 = 0 V, Logic 1 = V₊; C_L = 50 pF)

Parameter	Symbol	Min	Typ	Max	Unit
Internal Oscillator Timing					
Internal Oscillator Frequency (Note 23)	f _{osc}	32	64	100	kHz
Internal Oscillator Drift Over Temperature	-	-	-0.02	-	%/°C
Serial Port Timing					
Serial Clock Frequency (Note 24)	SCLK	-	-	2	MHz
SCLK High to Enter Sleep (Notes 24 and 25)	t _{SLP}	200	-	2000	μs
SCLK Low to Exit Sleep (Notes 24 and 25)	t _{WAKE}	10	-	-	μs
Rise Times (Note 26)	t _{rise}	-	-	-	-
CSB		-	-	1.0	μs
SCLK		-	-	10	μs
SDO		-	50	-	ns
Fall Times (Note 26)	t _{fall}	-	-	-	-
CSB		-	-	1.0	μs
SCLK		-	-	10	μs
SDO		-	50	-	ns
Serial Clock					
Pulse Width High	t ₆	200	-	-	ns
Pulse Width Low	t ₇	200	-	-	ns
SDO Read Timing					
$\overline{\text{CS}}$ to Data Valid	t ₈	-	-	150	ns
SCLK Falling to New Data Bit	t ₉	-	-	150	ns
$\overline{\text{CS}}$ Rising to SDO Hi-Z	t ₁₀	-	-	150	ns
$\overline{\text{CS}}$ Falling to SCLK Rising	t ₁₁	200	-	-	ns

- Notes: 23. The internal oscillator in the CS5511/13 provides the master clock for performing conversions. Data is retrieved from the serial port using the SCLK input pin.
24. The minimum SCLK rate for the CS5511/13 assumes that SCLK is logic 0 when idle. When data is being read from the ADC, SCLK must be burst at a minimum rate of 10 kHz and with a minimum of a 10 percent duty cycle. Rates slower than this can potentially put the ADC into sleep as the sleep mode is entered after SCLK is logic 1 for t_{SLP} time.
25. On the CS5511/13, the serial clock (SCLK) is used to transfer data from the CS5511/13. If SCLK is held high (logic 1) for t_{SLP} or longer, the CS5511/13 enters sleep mode. To exit from sleep mode, SCLK must be held low (logic 0) for t_{WAKE} or longer.
26. Specified using 10% and 90% points on waveform of interest. Output loaded with 50 pF.

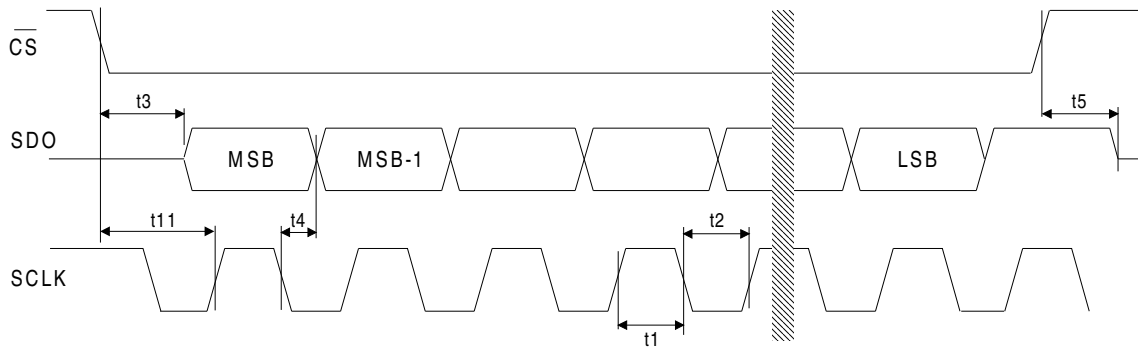

Figure 1. SDO Read Timing CS5510/12 (Not to Scale).

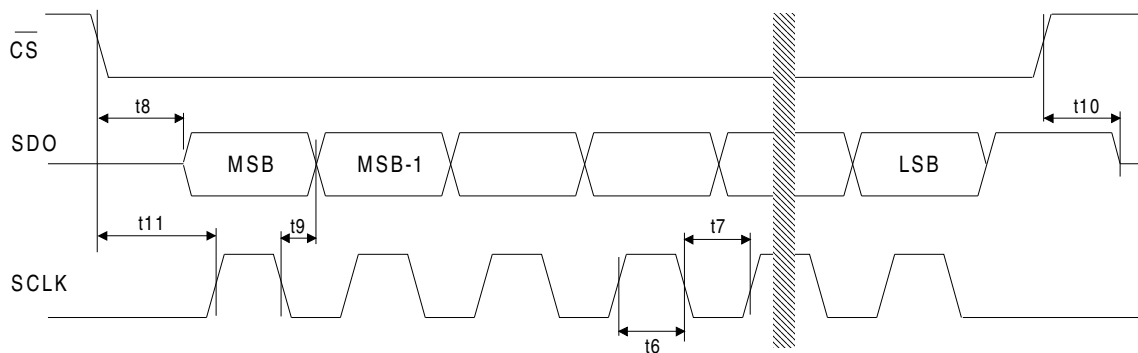

Figure 2. SDO Read Timing CS5511/13 (Not to Scale).

2. GENERAL DESCRIPTION

The CS5510/11/12/13 are low-cost, easy-to-use, $\Delta\Sigma$ analog-to-digital converters (ADCs) which use charge balance techniques to achieve 16-bit (CS5510/11) and 20-bit (CS5512/13) performance. The ADCs are available in a space-efficient, 8-pin, SOIC package and are optimized for measuring signals in weigh scale, process control, and other industrial applications.

To accommodate these applications, the ADCs include a fourth-order $\Delta\Sigma$ modulator and a digital filter. When configured with an external master clock of 32.768 kHz, the filter in the CS5510/12 provides better than 80 dB of simultaneous 50 and 60 Hz line rejection, and outputs conversion words at 53.5 Sps. The CS5511/13 include an on-chip oscillator which eliminates the need for an external clock source.

The CS5510/11/12/13 ADCs are designed to operate from a single +5 V supply or a variety dual-supply configurations and are optimized to digitize bipolar signals in industrial applications.

To achieve low cost, the CS5510/11/12/13 family of converters have no on-chip calibration features. The CS5510/11/12/13 offer very low offset drift, low gain drift, and excellent linearity.

2.1 Analog Input

The CS5510/11/12/13 provides a differential input span of approximately $\pm(0.80 \pm 0.08)$ times the dif-

ferential voltage reference ($V_{REF} - V_-$). This translates to typically ± 4.0 V fully differential when the reference voltage between V_{REF} and V_- is 5 V, and typically ± 2.0 V fully differential at 2.5 V.

Note: When a smaller reference voltage is used, the resulting code widths are smaller. Since the output codes exhibit more changing codes for a fixed amount of noise, the converter appears noisier.

2.1.1 Analog Input Model

Figure 3 illustrates the input model for the AIN pins. The model includes a coarse/fine charge buffer which reduces the dynamic current demands from the signal source. The buffer is designed to accommodate rail-to-rail (common-mode plus signal) input voltages. Typical CVF (sampling) current is about 10 nA. Application Note 30, "Switched-capacitor A/D Input Structures", details various input architectures.

2.2 Voltage Reference Input

The voltage between the V_{REF} and V_- pins of the converter determines the voltage reference for the converter. This voltage can be as low as 250 mV, or as great as $(V_+) - (V_-)$. The V_{REF} pin can be connected directly to the V_+ pin. This will establish a voltage reference equal to $(V_+) - (V_-)$ for the converter. The effective resolution of the part (noise-free bits for a single sample with no averaging) will vary with V_{REF} . Figure 4 shows how the V_{REF} voltage affects the noise-free resolution of the

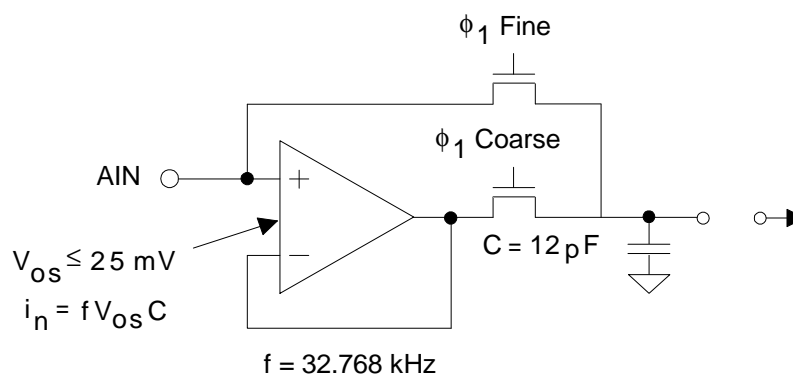

Figure 3. Input models for AIN+ and AIN- pins.

CS5512/13. The CS5510/11 follow the same curve, but are limited to 16 bits of resolution. Note that the reference voltage should not be established prior to having the supply voltages on the V+ and V- pins.

2.2.1 Voltage Reference Input Model

Figure 5 illustrates the input model for the VREF pin. It includes a coarse/fine charge buffer which reduces the dynamic current demand of the exter-

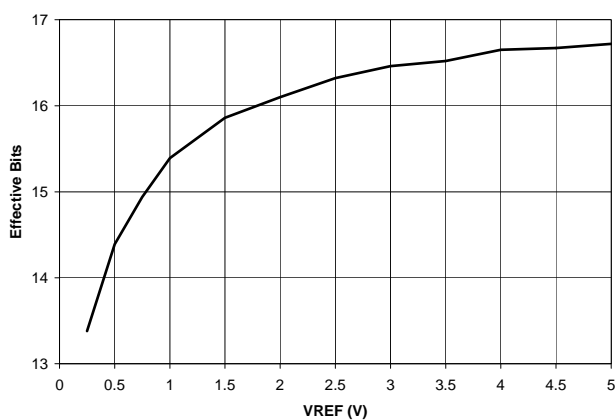

Figure 4. CS5512/13 Measured Noise-Free Bits vs. VREF.

nal reference. Typical CVF (sampling) current is about 6 nA (See Figure 5).

The nominal input span of the converter is defined to be a bipolar span equal to $\pm(VREF - V-)*(0.80 \pm 0.08)$.

2.3 Power Supply Arrangements

The CS5510/11/12/13 are designed to operate from single or dual supplies. Figure 6 illustrates the CS5510/11/12/13 connected with a single +5 V supply to measure differential inputs relative to a common mode of 2.5 V. Figure 7 illustrates the CS5510/11/12/13 connected with ± 2.5 V analog supplies to measure ground-referenced, bipolar signals. It is not necessary that the dual supplies on the ADCs be balanced, however, they must sum to five volts. Figure 8 illustrates the ADCs configured with $V+ = +3.3$ V and $V- = -1.7$ V, accommodating a +3.3 V digital supply.

2.3.1 Digital Logic Levels

The many power supply configurations available in the CS5510/11/12/13 allow for a wide range of digital logic levels. The logic-high input and output levels are determined by the V+ pin. The logic-low output on SDO is referenced to and driven by the current logic-low voltage on CS. Since the CS5510/11/12/13 do not include a dedicated

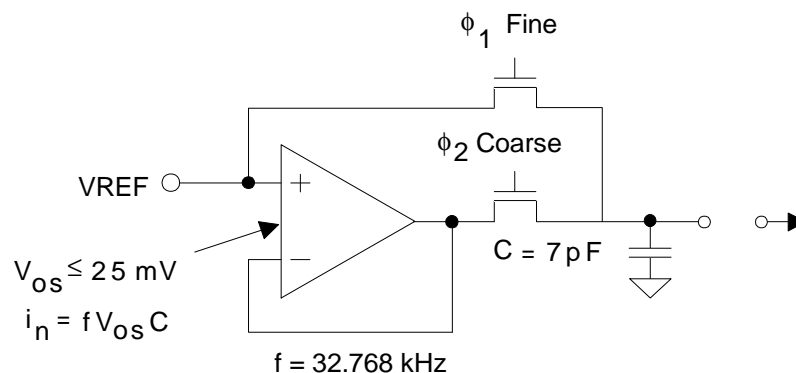

Figure 5. Input model for VREF pin.

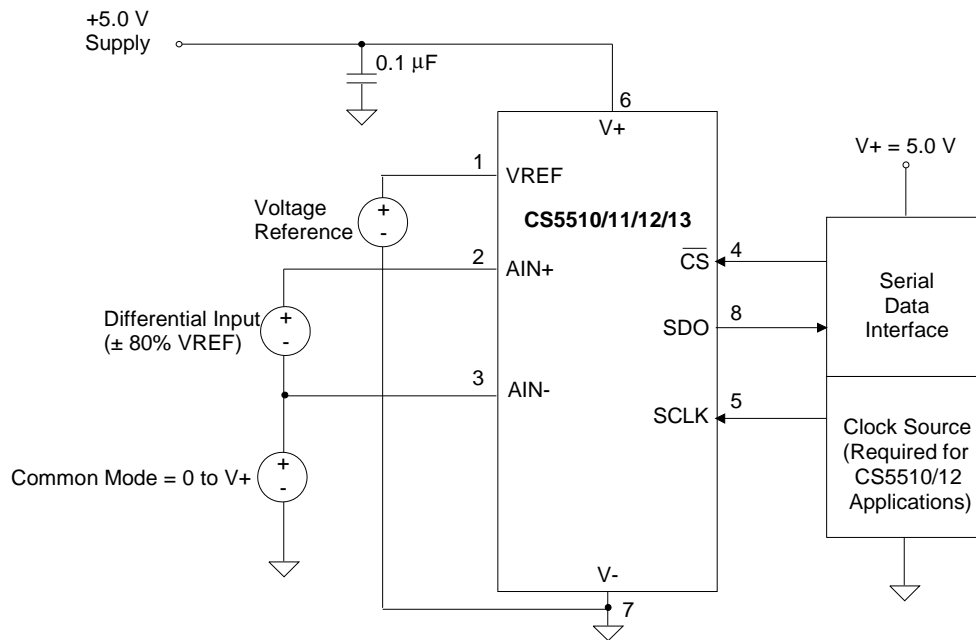

Figure 6. CS5510/11/12/13 Configured with a +5.0 V Analog Supply.

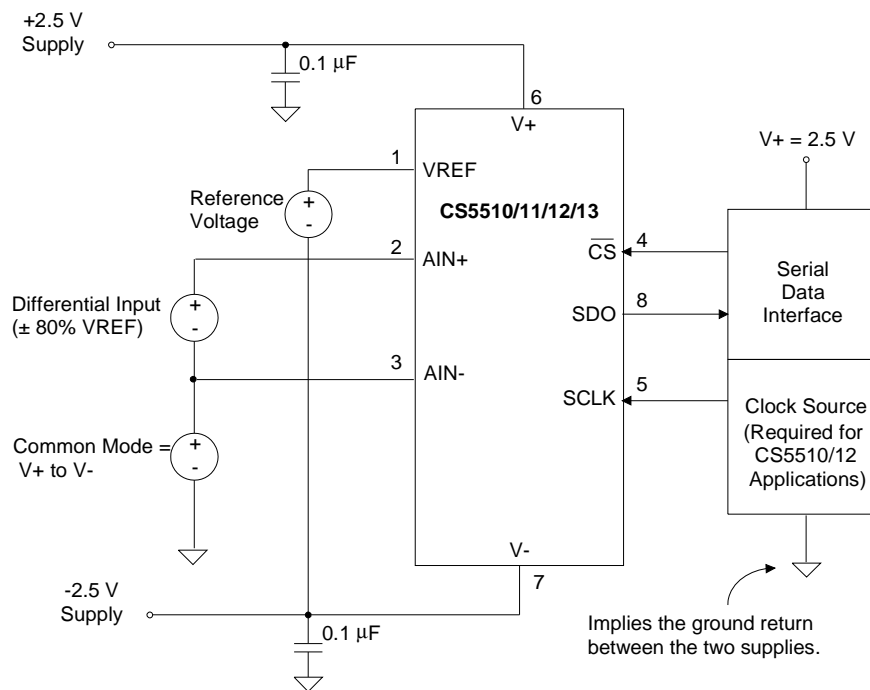

Figure 7. CS5510/11/12/13 Configured with ±2.5 V Analog Supplies.

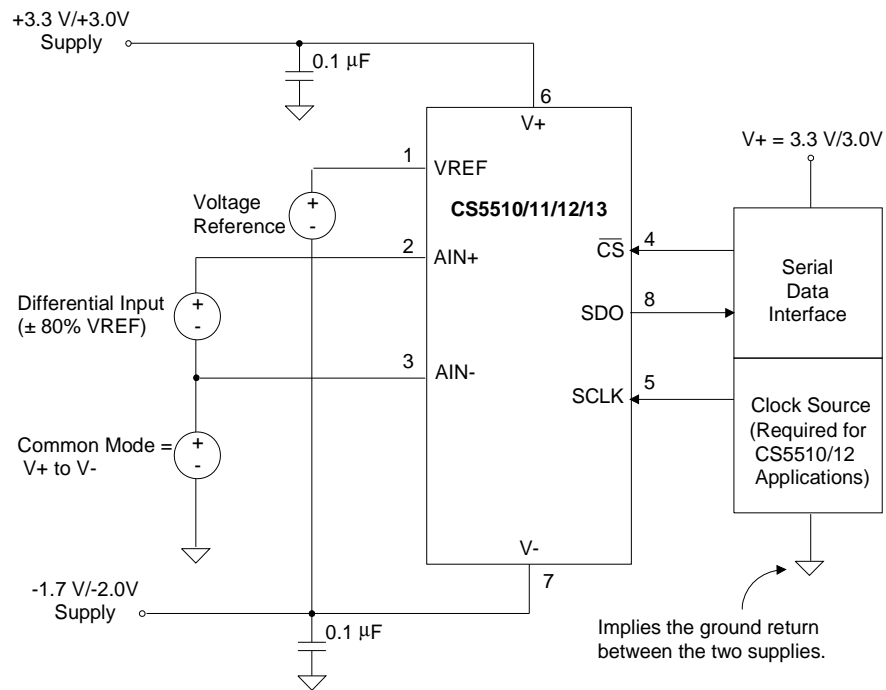

Figure 8. CS5510/11/12/13 Configured with V+ = +3.3 V and V- = -1.7 V; or V+ = +3.0 V and V- = -2.0 V.

ground pin, \overline{CS}_{LOW} defines the logic-low level for the digital interface. Figures 9 and 10 illustrate the threshold levels of the CS5510/11/12/13 serial interface (\overline{CS} , SCLK, and SDO).

To accommodate opto-isolators, the SCLK input is designed with a Schmitt-trigger to allow an opto-isolator with slower rise and fall times to directly drive the pin. Additionally, SDO is capable of sinking up to 1 mA or sourcing up to 5 mA to directly drive an opto-isolator LED. SDO will have less than a 600 mV loss in the drive voltage when sinking or sourcing its current. As shown in Figure 11, the \overline{CS} signal provides the sink current path for the SDO pin when its voltage is low (i.e. the voltage specified for SDO is relative to \overline{CS}_{LOW}).

2.4 Clock Generator

The CS5510/12 and CS5511/13 provide distinct modes for generating the master clock for the ADCs. The CS5510/12 uses the SCLK input pin as its operating clock. The CS5511/13 has an on-chip oscillator that provides its master clock. The SCLK pin on the CS5511/13 is used only to read data and to put the part into sleep mode.

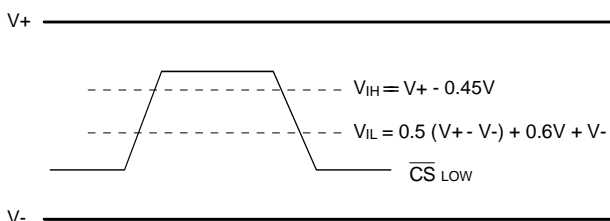

Figure 9. \overline{CS} and SCLK Digital Input Levels.

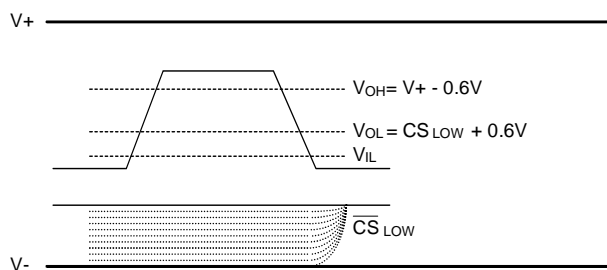

Figure 10. SDO Digital Output Levels.

2.4.1 External Clock Source for CS5510/12

The user must provide an external (CMOS compatible) clock to the CS5510/12. The clock is input to SCLK where it is then divided down to provide the master clock for the ADC. The output word rate (OWR) for the CS5510/12 is derived from the SCLK, and is equal to $SCLK/612$. Figure 12 illustrates an external 32.768-kHz, CMOS-compatible clock oscillator that a user might consider.

Another clock generation option is to use a microcontroller. Some microcontrollers have dedicated timer/counter circuitry which can generate a clock signal on an output pin with no software overhead. Such a microcontroller circuit is shown in Figure 13.

Note that the CS5510 can operate with an external, CMOS-compatible clock at frequencies up to 130 kHz, and the CS5512 can operate with an external clock of up to 200 kHz with a maximum 22 ns of jitter. Linearity performance is degraded slightly with higher clock speeds, as shown in Figures 14 and 15. The noise performance of the parts, however, is not affected by higher clock speeds.

2.4.2 Internal Oscillator for CS5511/13

The CS5511/13 includes an on-chip oscillator. This oscillator provides the master clock for the

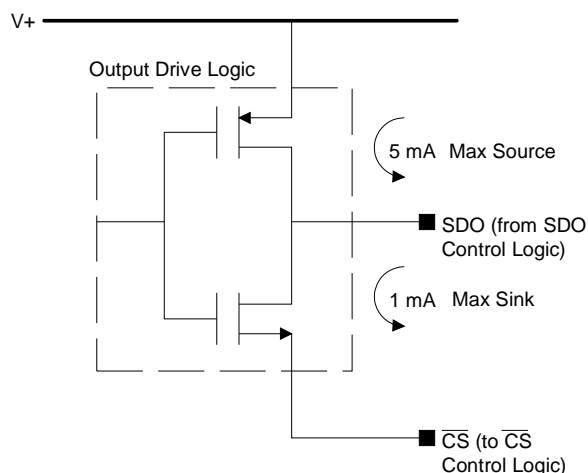
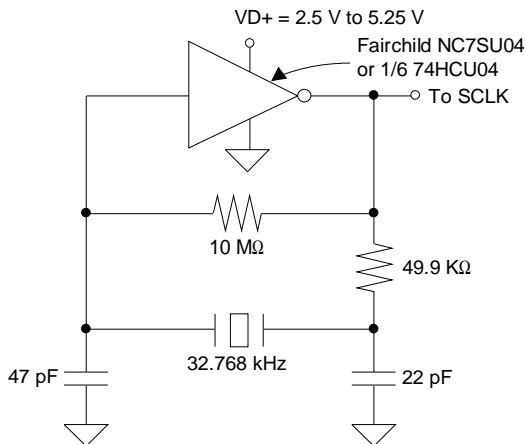
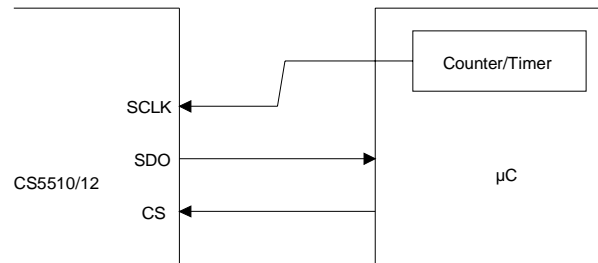

Figure 11. Serial Port Output Drive Logic.

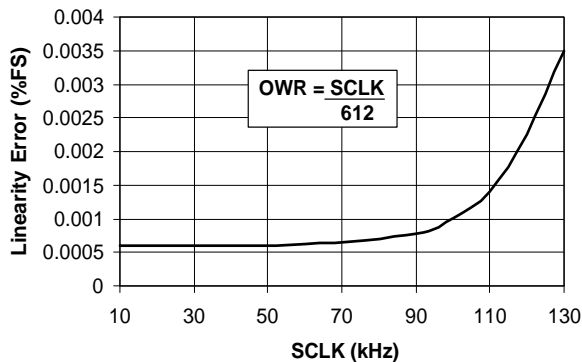
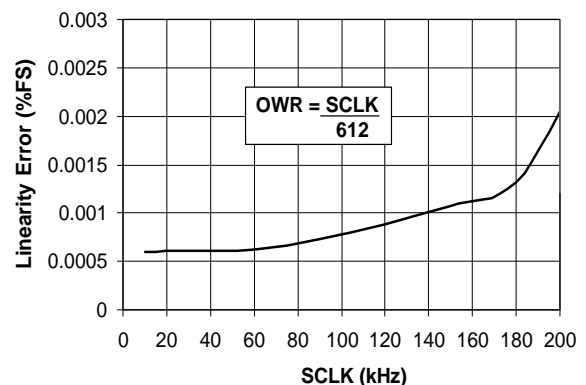

Figure 12. External (CMOS Compatible) Clock

Figure 13. Using a Microcontroller as a Clock

CS5511/13 and oscillates at 64 kHz \pm 32 kHz. The output word rate (OWR) for the CS5511/13 is derived from the internal oscillator, and is equal to $f_{osc}/612$. Due to the part-to-part variances in the oscillator frequency, the OWR of the CS5511/13 can vary between 53 Sps and 159 Sps.

2.5 Performing Conversions

After power and a clock source are established to the CS5510/11/12/13, the ADCs begin performing conversions. The three sections that follow explain

how to read conversion data from each ADC, and decode the conversion word into the respective flag and data bits. Keep in mind that in the CS5510/12, SCLK provides the external clock source for the converter. Data is clocked from the CS5510/12 at the rate set by the external clock source (typically 32.768 kHz). The CS5511/13 provides an on-chip oscillator for the master clock. In the CS5511/13, SCLK is asynchronous to the on-chip oscillator and can be clocked at a rate up to 2 MHz.

Figure 14. Typical Linearity Error for CS5510.

Figure 15. Typical Linearity Error for CS5512.

2.5.1 Reading Conversions - CS5510/12

After power-up, the CS5510/12 will begin converting once a clock source is applied to the SCLK pin. When a conversion has completed, and there is new data in the output register, the SDO line will fall to a logic-low level if \overline{CS} is also at a logic-low state (SDO will always be high-impedance when \overline{CS} is high). If \overline{CS} is low at the end of the conversion cycle, SDO will fall on the rising edge of an SCLK. After SCLK falls, the next SCLK cycle (high, then low) will begin clocking out the data. The first data bit therefore, is 1-½ SCLK cycles wide. Twenty-four SCLK cycles (after the initial high-low transition) are needed to retrieve the conversion word from the device (see Figures 16 and 17). The data bits can be read on the rising edge of SCLK, and the next data bit is output to SDO on the falling edge of SCLK. Once the entire data word has been read, SDO will return to a logic-high state until there is a new conversion word available. If \overline{CS} is at a logic-high at the end of the conversion cycle, the data will not be shifted out of the part until \overline{CS} is brought to a logic-low state during the next conversion cycle. If a new conversion becomes available while the current data is being read, the data register will not be updated, and the new conversion word will be lost. The user need not read every conversion. If the user chooses not to read a conversion, \overline{CS} should remain at a logic-high state for the duration of the conversion cycle. Note that if \overline{CS} goes to a logic-high state during a read, the current conversion data will be lost and replaced

by a new conversion word when the new conversion data is available.

2.5.2 Reading Conversions - CS5511/13

After power-up, the CS5511/13 begins converting and updating the output register. When there is new data in the output register (at the end of a conversion cycle) the SDO line will fall to a logic-low level if \overline{CS} is also at a logic-low state (SDO will always be high-impedance when \overline{CS} is high). Twenty-four SCLK cycles are needed to retrieve the conversion word from the device (see Figures 18 and 19). The data bits can be read on the rising edge of SCLK, and the next data bit is output to SDO on the falling edge of SCLK. Once the entire data word has been read, SDO will return to a logic-high state until there is a new conversion word available. If new conversions become available while the current data is being read, the data register will not be updated, and the new conversions will be lost. The user need not read every conversion. If the user chooses not to read a conversion after SDO falls, SDO will rise seventeen oscillator clock cycles (of the internal oscillator) before the next conversion word is available and then fall again to signal that the conversion is complete. Note that if a conversion word is not read before the next conversion word is ready, or if \overline{CS} goes to a logic-high state during a read, the current conversion data will be lost and replaced by a new conversion word when the new conversion data is available.

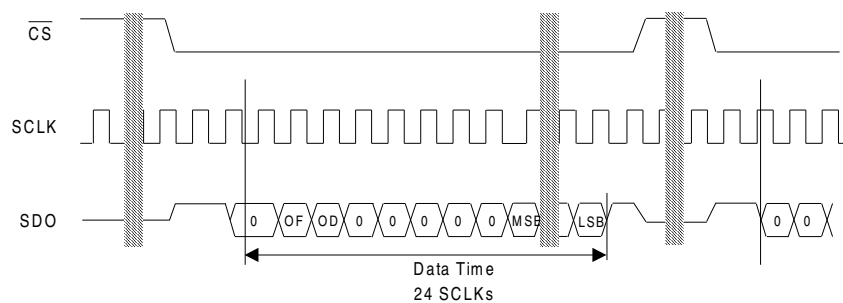

Figure 16. Data Word Timing for the CS5510.

2.5.3 Output Coding

As shown in Tables 1 and 2, the CS5510/11/12/13 present output conversions as 24-bit conversion words. The first bit of the conversion word indicates that a conversion is done through SDO falling from a logic high to a logic low level. The first and the fourth bits output will always be zero. The second and third bits are error flags, representing an overflow or oscillation condition. In the CS5510/11, there are four more bits of zero, and the remaining 16 bits are the conversion data, output MSB first (Table 2). In the CS5512/13, the final

20 bits are the conversion data, which is output MSB first (Table 1).

Bits D22-D21 are the two flag bits. The OF (Over-range Flag) bit is set to a logic 1 any time the input signal is more positive than positive full scale, or more negative than negative full scale. It is cleared back to logic 0 whenever a conversion word occurs which is not overranged. The OD (Oscillation Detect) bit is set to a logic 1 any time that an oscillatory condition is detected in the modulator. This does not occur under normal operating conditions, but may occur whenever the input to the converter is ex-

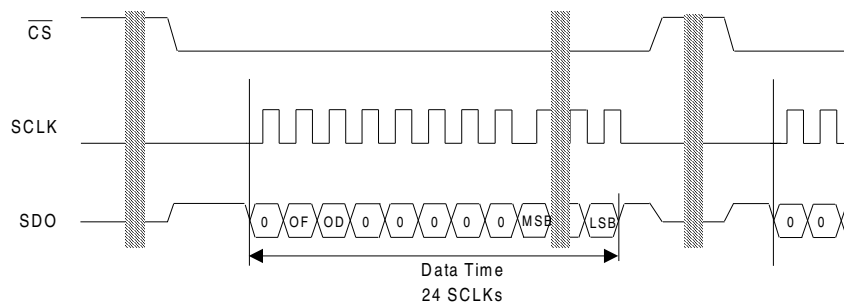

Figure 17. Data Word Timing for the CS5511.

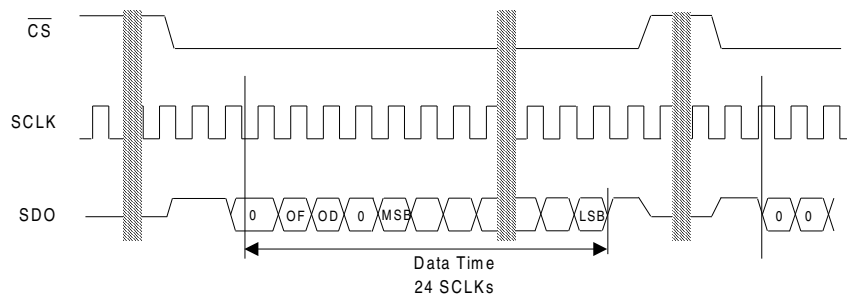

Figure 18. Data Word Timing for the CS5512.

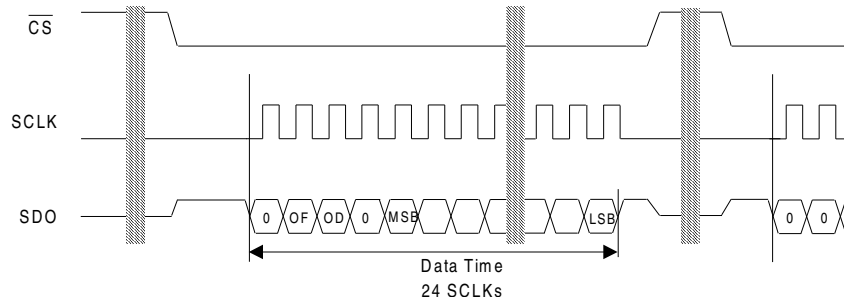

Figure 19. Data Word Timing for the CS5513.

Bipolar Input Voltage	Two's Complement (20-Bit)	Two's Complement (16-Bit)
>(VFS-1.5 LSB)	7FFFF	7FFF
VFS-1.5 LSB	7FFFF ----- 7FFFE	7FFF ----- 7FFE
-0.5 LSB	00000 ----- FFFFF	0000 ----- FFFF
-VFS+0.5 LSB	80001 ----- 80000	8001 ----- 8000

Note: VFS in the table equals the voltage between AIN+ and AIN-. See text about error flags under overrange conditions.

Table 3. CS5510/11/12/13 Output Coding.

cessively overranged. If the OD bit is set, the conversion data bits can be completely erroneous. The OD flag bit will be cleared to logic 0 four output words after the modulator becomes stable again. The OD flag can occur independent of OF with a spike on the input. Both flag bits should be tested if any overrange condition occurs.

Table 3 illustrates the output coding for the CS5510/11/12/13. Conversions are output as two's complement values representing bipolar input signals.

2.5.4 Digital Filter

The CS5510/11/12/13 have a modified Sinc⁴ digital filter that provides CLK/612 Hz conversion rates

(CLK represents SCLK for the CS5510/12 and the internal oscillator for the CS5511/13). The filters are optimized to yield better than 80 dB rejection between 47 Hz to 63 Hz (i.e. 80 dB minimum rejection for both 50 Hz and 60 Hz) when the master clock is 32.768 kHz. The filter has a response as shown in Figure 20. Table 4 shows the filter response for frequencies from 38 Hz to 71 Hz. Note that the response of the CS5511/13 will be similar, but the frequencies scale with the on-chip oscillator's frequency, which can be from 32 kHz to 96 kHz (i.e. conversion rates can vary between 53 Sps to 159 Sps). Further note that after initial power up, or after returning from sleep mode, the filter requires four conversion cycles to produce a

D23	D22	D21	D20	D19	D18	D17	D16	D15	D14	D13	D12
0	OF	OD	0	MSB	18	17	16	15	14	13	12
D11	D10	D9	D8	D7	D6	D5	D4	D3	D2	D1	D0
11	10	9	8	7	6	5	4	3	2	1	LSB

Table 1. CS5512/13 Output Conversion Data Register Description (Flags + 20 bits).

D23	D22	D21	D20	D19	D18	D17	D16	D15	D14	D13	D12
0	OF	OD	0	0	0	0	0	MSB	14	13	12
D11	D10	D9	D8	D7	D6	D5	D4	D3	D2	D1	D0
11	10	9	8	7	6	5	4	3	2	1	LSB

Table 2. CS5510/11 Output Conversion Data Register Description (Flags + 16 bits).

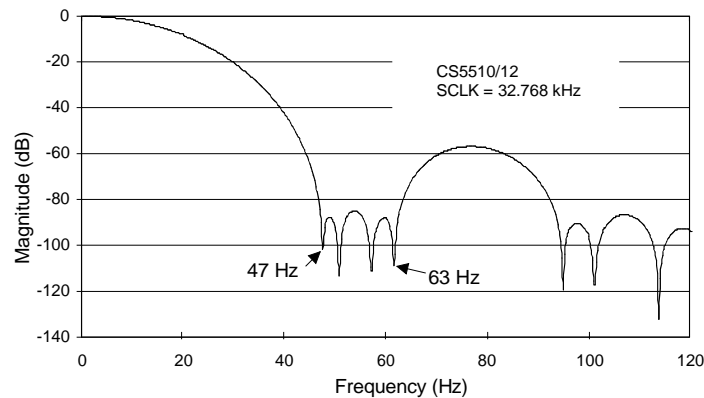

Figure 20. Digital Filter Response.

Frequency (Hz)	Rejection (dB)	Frequency (Hz)	Rejection (dB)	Frequency (Hz)	Rejection (dB)	Frequency (Hz)	Rejection (dB)
38	37	47	84	56	91	65	73
39	39	48	92	57	109	66	69
40	42	49	88	58	94	67	66
41	46	50	92	59	89	68	64
42	49	51	105	60	88	69	63
43	54	52	89	61	92	70	61
44	58	53	86	62	104	71	60
45	64	54	85	63	84	-	-
46	72	55	87	64	77	-	-

Table 4. Digital Filter Response at 32.768 kHz.

valid conversion due to the modified Sinc⁴ filter characteristics.

2.5.5 Multiplexed Applications

The settling performance of the CS5510/11/12/13 in multiplexed applications is determined by the Sinc⁴ filter. To settle, a step input requires 4 full conversion cycles after the analog input has switched. In this case, the throughput is reduced by a factor of four as the first three conversions after the step is applied will not be fully settled.

If the application does not require the maximum throughput possible from the ADC, the multiplexer can be switched at any time. In this case, the system must wait for at least five conversion cycles for a fully-settled result from the ADC.

If maximum throughput is required in a multiplexed application, the multiplexer must be switched at the correct time during the data collection process. For maximum throughput with the CS5510/12, switching of a multiplexer should occur 595 SCLK cycles after SDO falls. For maximum throughput with the CS5511/13, switching of a multiplexer should occur on the rising edge of SDO during a conversion in which the data word is not read. The conversion data that is immediately available when SDO falls again is valid, and represents the analog input from the previous multiplexer setting. The next three conversions from the part will be unsettled values, and the fourth conversion will represent a fully-settled result from the new multiplexer setting. The multiplexer should be switched again at the appro-

appropriate time during the third conversion cycle to ensure the maximum possible throughput.

2.6 Digital Off-chip System Calibration

The CS5510/11/12/13 exhibit excellent linearity with low offset and gain drift, without the need for calibration. If precision voltage measurements are required by the system, however, software-based offset and gain calibration can be performed by the system.

To perform a software offset calibration, the “zero-point” of the system should be established by applying an input to the system equal to zero. Then, the user can obtain a conversion and store it in memory as the system’s zero point (ZP). This number can then be used as the zero point for any subsequent conversion words. In the 20-bit devices (CS5512 and CS5513), multiple conversions can be averaged to arrive at a more accurate offset value. In the 16-bit devices (CS5510 and CS5511), averaging may not be meaningful, because the noise will be below the size of one LSB when using nominal voltages for VREF (2.5 V).

A software gain calibration can be performed by bringing the system to a known calibration Voltage value (Vcal) and acquiring a conversion (note that Vcal should be low enough to compensate for the possible gain error of the ADC). Multiple conversions can be averaged at this point to improve the accuracy of the calibration. The code obtained from this conversion is the real value (Cr) of the calibration Voltage input, and will differ from the ideal value. The ideal value for this conversion (Ci)

will be equivalent to: $0x7FFF \cdot V_{cal} / (0.80 \cdot V_{ref})$ for the CS5510/11, and $0x7FFFF \cdot V_{cal} / (0.80 \cdot V_{ref})$ for the CS5512/13. The gain error (GE) is equal to: $(Cr - ZP) / Ci$. To correct for both offset and gain error in subsequent conversions, subtract the offset error, and then divide by the gain error.

2.7 Power Consumption, Sleep and Reset

The CS5510/11/12/13 accommodates two power modes: *normal* and *sleep*. The normal mode is the default mode and is entered after power is established to the ADC. In normal mode, the ADCs typically consumes 2.5 mW. Sleep is entered when the user leaves SCLK high for at least 200 μ s. The ADCs are guaranteed to be in sleep after SCLK is high (logic 1) for 2 ms. The sleep mode reduces the consumed power to less than 10 μ W when \overline{CS} is high (logic 1). If \overline{CS} is low (logic 0) at this time, the SDO drive logic will still be active, and the consumed sleep power will be greater. To exit sleep and return to normal mode, the user must return SCLK low for at least 10 μ s. After a sleep is exited, the ADCs reset all their internal logic, including their digital filters, and begin performing conversions. Since the filters are reset, the first three conversion after returning to normal mode will not be fully settled.

2.8 PCB Layout

The CS5510/11/12/13 should be placed entirely over the analog ground. Place the analog-digital plane split immediately adjacent to the digital pins of the chip.

3. PIN DESCRIPTIONS

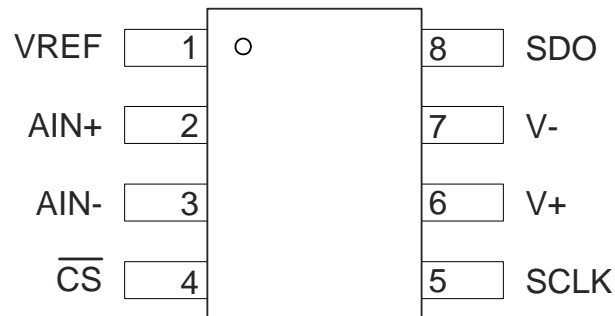

Control Pins and Serial Data I/O

\overline{CS} - Chip Select, Pin 4

\overline{CS} is a dual function pin, which determines the state of SDO, as well as the digital logic-low output level. When \overline{CS} is low, SDO will be active. When high, the SDO pin will output a high-impedance state. The logic-low level of SDO will match the active-low voltage on \overline{CS} .

SDO - Serial Data Output, Pin 8

SDO is the serial data output. It will output a high-impedance state if $\overline{CS} = 1$. The logic-low level of SDO will match the active-low voltage on \overline{CS} .

SCLK - Serial Clock Input, Pin 5

SCLK is the serial bit-clock which controls the shifting of data from the ADCs. This input goes through a Schmitt trigger to allow for slow rise and fall time signals. If held high, the device will enter sleep mode. In the CS5510/12, this input is also used as a master clock source which determines conversion speeds and throughput. In the CS5511/13, SCLK is only used to read the conversion data and put the part in sleep mode.

Measurement and Reference Inputs

AIN+, AIN- - Differential Analog Input, Pins 2, 3

Differential input pins into the device

VREF - Voltage Reference Input, Pin 1

Input Voltage which establishes the voltage reference, with respect to V-, for the on-chip modulator

Power Supply Connections

V+ - Positive Power, Pin 6

Positive supply voltage

V- - Negative Supply, Pin 7

Negative supply voltage

4. SPECIFICATION DEFINITIONS

Linearity Error

The deviation of a code from a straight line which connects the two end points of the A/D Converter transfer function. One end point is located 1/2 LSB below the first code transition and the other end point is located 1/2 LSB beyond the code transition to all ones. Units in percent of full-scale.

Differential Nonlinearity

The deviation of a code's width from the ideal width. Units in LSBs.

Full Scale Error

The deviation of the last code transition from the ideal $[(V_{REF}) - (V_-)] - 3/2 \text{ LSB}$. Units are in LSBs.

Bipolar Offset

The deviation of the mid-scale transition (111...111 to 000...000) from the ideal (1/2 LSB below the voltage on the AIN- pin). Units are in LSBs.LK

5. ORDERING INFORMATION

Device Number	Oscillator	Resolution	Linearity Error (Max)	Temperature Range	Package
CS5510-ASZ	External	16 Bits	±0.003%	-40°C to +85°C	8-pin SOIC Lead-free
CS5511-ASZ	Internal				
CS5512-BSZ	External	20 Bits	±0.0015%		
CS5513-BSZ	Internal				

6. ENVIRONMENTAL, MANUFACTURING, & HANDLING INFORMATION

Model Number	Peak Reflow Temp	MSL Rating*	Max Floor Life
CS5510-ASZ	260 °C	3	7 Days
CS5511-ASZ			
CS5512-BSZ			
CS5513-BSZ			

* MSL (Moisture Sensitivity Level) as specified by IPC/JEDEC J-STD-020.

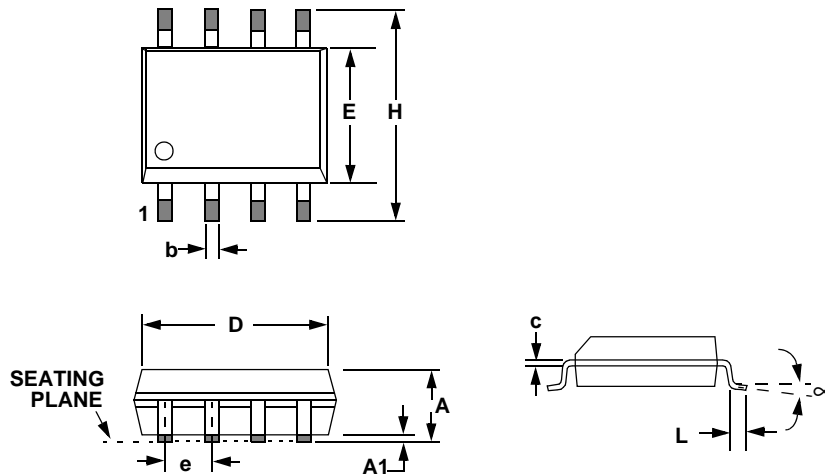
7. PACKAGE DIMENSIONS
8L SOIC (208 MIL BODY) PACKAGE DRAWING

DIM	INCHES			MILLIMETERS		
	MIN	NOM	MAX	MIN	NOM	MAX
A	0.076	0.080	0.084	1.93	2.03	2.13
A1	0.004	0.007	0.010	0.10	0.175	0.25
b	0.013	0.016	0.020	0.33	0.406	0.51
C	0.006	0.008	0.010	0.15	0.20	0.25
D	0.206	0.208	0.210	5.23	5.28	5.33
E	0.204	0.208	0.212	5.18	5.28	5.38
e	0.040	0.050	0.060	1.02	1.27	1.52
H	0.302	0.310	0.318	7.67	7.88	8.08
L	0.019	0.025	0.030	0.48	0.64	0.76
∞	0°	4°	8°	0°	4°	8°

EIAJ PACKAGE

Controlling Dimension is Inches

8. REVISION HISTORY

Revision	Date	Changes
F2	MAR 2005	Added lead-free (Pb) device ordering information.
F3	AUG 2005	Updated lead-free (Pb) device ordering information. Added MSL data.
F4	JUL 2009	Removed devices containing lead (Pb) from ordering information.

Contacting Cirrus Logic Support

For all product questions and inquiries contact a Cirrus Logic Sales Representative.

To find the one nearest to you go to www.cirrus.com

IMPORTANT NOTICE

Cirrus Logic, Inc. and its subsidiaries ("Cirrus") believe that the information contained in this document is accurate and reliable. However, the information is subject to change without notice and is provided "AS IS" without warranty of any kind (express or implied). Customers are advised to obtain the latest version of relevant information to verify, before placing orders, that information being relied on is current and complete. All products are sold subject to the terms and conditions of sale supplied at the time of order acknowledgment, including those pertaining to warranty, indemnification, and limitation of liability. No responsibility is assumed by Cirrus for the use of this information, including use of this information as the basis for manufacture or sale of any items, or for infringement of patents or other rights of third parties. This document is the property of Cirrus and by furnishing this information, Cirrus grants no license, express or implied under any patents, mask work rights, copyrights, trademarks, trade secrets or other intellectual property rights. Cirrus owns the copyrights associated with the information contained herein and gives consent for copies to be made of the information only for use within your organization with respect to Cirrus integrated circuits or other products of Cirrus. This consent does not extend to other copying such as copying for general distribution, advertising or promotional purposes, or for creating any work for resale.

CERTAIN APPLICATIONS USING SEMICONDUCTOR PRODUCTS MAY INVOLVE POTENTIAL RISKS OF DEATH, PERSONAL INJURY, OR SEVERE PROPERTY OR ENVIRONMENTAL DAMAGE ("CRITICAL APPLICATIONS"). CIRRUS PRODUCTS ARE NOT DESIGNED, AUTHORIZED OR WARRANTED FOR USE IN PRODUCTS SURGICALLY IMPLANTED INTO THE BODY, AUTOMOTIVE SAFETY OR SECURITY DEVICES, LIFE SUPPORT PRODUCTS OR OTHER CRITICAL APPLICATIONS. INCLUSION OF CIRRUS PRODUCTS IN SUCH APPLICATIONS IS UNDERSTOOD TO BE FULLY AT THE CUSTOMER'S RISK AND CIRRUS DISCLAIMS AND MAKES NO WARRANTY, EXPRESS, STATUTORY OR IMPLIED, INCLUDING THE IMPLIED WARRANTIES OF MERCHANTABILITY AND FITNESS FOR PARTICULAR PURPOSE, WITH REGARD TO ANY CIRRUS PRODUCT THAT IS USED IN SUCH A MANNER. IF THE CUSTOMER OR CUSTOMER'S CUSTOMER USES OR PERMITS THE USE OF CIRRUS PRODUCTS IN CRITICAL APPLICATIONS, CUSTOMER AGREES, BY SUCH USE, TO FULLY INDEMNIFY CIRRUS, ITS OFFICERS, DIRECTORS, EMPLOYEES, DISTRIBUTORS AND OTHER AGENTS FROM ANY AND ALL LIABILITY, INCLUDING ATTORNEYS' FEES AND COSTS, THAT MAY RESULT FROM OR ARISE IN CONNECTION WITH THESE USES.

Cirrus Logic, Cirrus, and the Cirrus Logic logo designs are trademarks of Cirrus Logic, Inc. All other brand and product names in this document may be trademarks or service marks of their respective owners.

SPI is a trademark of Motorola, Inc.